

Modular Cooking Range Line EVO700 Electric Hob Cooking Top 400 mm

ITEM # _____

MODEL # _____

NAME # _____

SIS # _____

AIA # _____



372027 (Z7HOED2000)

Electric hob cooking top, half
module

Short Form Specification

Item No. _____

High efficiency 5.3 kW infrared heating elements. Large flat cooking surface in mild steel allows for the use of a number of various sized pots and pans, all easily moved across the surface without lifting. Exterior panels in stainless steel with Scotch Brite finish. One piece pressed work top in 1.5 mm thick stainless steel. Right-angled side edges to allow flush-fitting junction between units.

Main Features

- 5.3 kW infrared heating elements can reach a maximum temperature of 400°C.
- Durable mild steel cooking plate, easy to clean.
- Various sizes of pans can be used at the same time due to large surface area with no intermediate sectors.
- Pans can easily be moved from one area to another without lifting.
- All major compartments located in front of unit for ease of maintenance.
- Top configuration allows installation on ambient base only (not possible to install on refrigerated nor freezer base).
- Suitable for countertop installation.

Construction

- All exterior panels in Stainless Steel with Scotch Brite finishing.
- One piece pressed 1.5 mm work top in Stainless steel.
- Model has right-angled side edges to allow flush fitting joints between units, eliminating gaps and possible dirt traps.
- IPx4 water protection.

APPROVAL: _____

Optional Accessories

- Junction sealing kit PNC 206086
- Support for bridge type installation, 800 mm PNC 206137
- Support for bridge type installation, 1000 mm PNC 206138
- Support for bridge type installation, 1200 mm PNC 206139
- Support for bridge type installation, 1600 mm PNC 206141
- Support for bridge type installation, 400 mm PNC 206154
- Frontal handrail 400 mm PNC 206166
- Frontal handrail 800 mm PNC 206167
- Large handrail (portioning shelf) 400 mm PNC 206185
- Large handrail (portioning shelf) 800 mm PNC 206186
- Frontal handrail 1200 mm PNC 206191
- Frontal handrail 1600 mm PNC 206192
- Right and left side handrails PNC 206240
- Water column with swivel arm (water column extension not included) PNC 206289
- Water column extension PNC 206291
- Chimney upstand, 400 mm PNC 206303
- 2 side covering panels, height 250 mm, depth 700 mm PNC 206320
- Chimney grid net, 400mm PNC 206400

Front

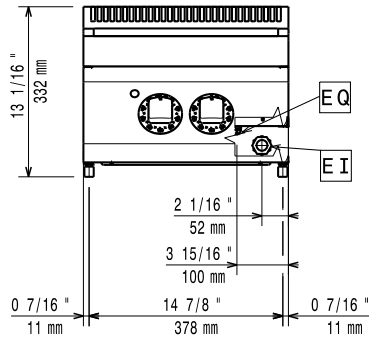

Side

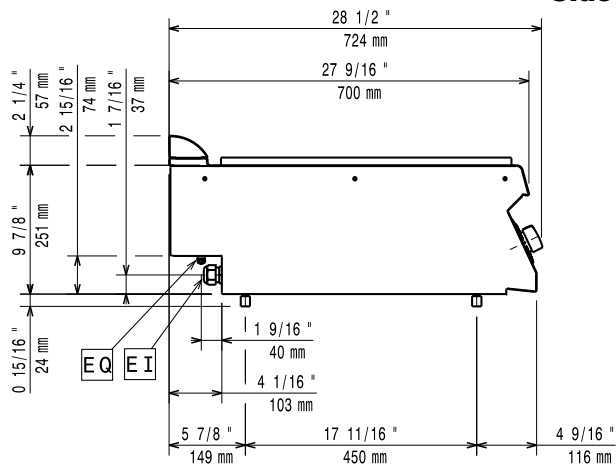

EQ = Equipotential screw
EI = Electrical inlet (power)

Top

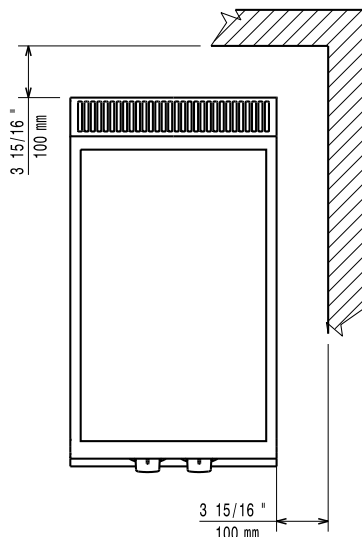

Electric

Supply voltage:

372027 (Z7HOED2000) 380-400 V/3N ph/50/60 Hz

Total Watts:

5 kW

Predisposed for:

380-400V 3N~ 50/60Hz 4.5-5kW

Key Information:

External dimensions, Width: 400 mm

External dimensions, Depth: 700 mm

External dimensions, Height: 250 mm

Net weight: 47 kg

Shipping weight: 42 kg

Shipping height: 530 mm

Shipping width: 460 mm

Shipping depth: 820 mm

Shipping volume: 0.2 m³

If appliance is set up or next to or against temperature sensitive furniture or similar, a safety gap of approximately 150 mm should be maintained or some form of heat insulation fitted.

Certification group: N7ETE